

**BROEN BALLOMAX®**  
STANDARD TRUNNION BALL VALVES

Double Block & Bleed



# CONTENTS

I.	INTRODUCTION .....	3
	Technical Manual Release Date .....	4
	BROEN A/S and BROEN Inc.....	5
	The Product .....	5
	Code and Compliance.....	5
	Noteworthy Design Features .....	6
II.	QUALITY ASSURANCE AND CONTROL .....	7
	The BROEN Quality Management System.....	8
III.	ENGINEERING DETAILS .....	11
	Design and Engineering Data .....	12
	Design Features .....	13
	Data Sheet .....	15
	Extract from Catalog.....	16
IV.	TESTING CODE AND COMPLIANCE .....	21
	Test Procedure According to API-6D Section 10 with ISO 5208 Rate A Acceptance Criteria.....	22
	Hydrostatic Shell Test.....	22
	Hydrostatic Seat Test .....	22
	Supplementary Air Seat Test According to API 6D L.19 Type I and II (ISO 5208 Rate A) .....	23
	Valve Documentation.....	24
V.	STANDARD VALVE PROCEDURES.....	26
	Valve Preservation and Storage .....	27
	Valve Handling, Transportation, and Shipment .....	27
	Standard Installation Procedures.....	29
	Testing of Field Welds .....	31
	Hot Tapping .....	33
	Valve Operations .....	33
	Valve Maintenance.....	34
	Troubleshooting .....	34

## I. INTRODUCTION

Technical Manual Release Date

# BROEN

## BALLOMAX®

All information contained in this manual is the exclusive property of **BROEN Inc.** Any reproduction or use of the calculations, drawings, photographs, procedures, or instructions, either expressed or implied, is forbidden without the written permission of **BROEN Inc.** or its authorized agent.

Initial Release: June, 1997

Latest Revision: February 8, 2024. Prepared by: Bryan Ham

Approved By:

Mogens Laursen, CEO BROEN A/S

---

BROEN A/S

Ben Marchisio, President

---

BROEN Inc.

Copyright© 1997 all rights reserved  
By **BROEN Inc.**

**BROEN Inc.**  
6421 Lozano Dr  
Houston TX 77041  
Phone: 713-300-0480  
[www.broen.us](http://www.broen.us)

## **BROEN A/S and BROEN Inc.**

BROEN A/S was founded in 1948 in Denmark. Today it is part of the Aalberts Industries Group of the Netherlands. BROEN A/S is a global leader manufacturer of valves for District Heating and for the Natural Gas Industry. Recently BROEN A/S acquired Clorius, a manufacturer of products for temperature and pressure control.

**BROEN Inc, Birmingham, Alabama** was created in 1995 to provide the North American market production of Ball Valves to better serve our customers. We moved to **Houston, Texas** in 2016 to a new and larger facility, with greater capacity, to continue to provide fast deliveries, broader product range, and technical assistance when needed.

## **The Product**

The Flagship products for BROEN Inc. are the **BALLOMAX®** Ball Valves for Natural Gas Industry. Our **Full Port Standard Trunnion Mounted Valves** are covered in this technical manual. The valves are Double Block and Bleed, maintenance free and available in ANSI 150 and ANSI 300.

## **Code and Compliance**

BROEN Inc BALLOMAX® Ball Valves are produced in accordance with ISO 9001 and strictly adheres to its top quality management system. All BALLOMAX valve are fully traceable, meet or exceed the requirements of ANSI dimensions, API 6D, MSS-SP 72, and DOT Title 49, part 192. Each and every valve produced are Hydrostatically Tested per API 6D with a supplementary air test per ISO 5208. Test Certificates are available for every valve.

## Noteworthy Design Features

BALLOMAX® Non- Lubricated Standard Trunnion Mounted Full Port Ball Valves designed specifically for Natural Gas Distribution and Transmission Systems. Trunnion Mounted to assist with high differential pressure applications. Valves come with standard bleed function. All valves are tested to API 6D specifications.

- BROEN BALLOMAX® All Welded Standard Trunnion Mounted Valves are in Sizes ranging from 8” thru 24”
- Soft Seating is PTFE, AED+ Viton® or equal.
- Standard Trunnion mounted valves have standard with Bleed port in Trunnion to assure 100% seal ability testing assurance.
- We utilize a non-toxic water based primer that is user friendly and environmentally safe in production and field applications. We can specialty coat your valve to your company specifications in house such as 3M 323 Epoxy or Black Coal Tar Enamel.
- All BROEN BALLOMAX® Valves are provided with permanent labels with a unique serial number for trace ability. The label includes: Serial Number, Size, Pressure Class, Port size, Seat Material, and Materials of Construction
- Full Port Trunnion mounted Ball Valves are equipped to operate with Gear Operators. Horizontal Gear Operators with Hand wheel for above ground operations and Vertical Gears with 2” operating nut for below ground direct burial
- BROEN BALLOMAX® provides a Test Certificate of the hydrostatic test and air seat test. The Hydrostatic tests are per API-6D section 10, Par.3.1, 4.1. In addition the air test is per ISO 5208 rate A and is provided as our standard procedure.
- All BROEN BALLOMAX® Valves are equipped with a “Safety grounded stem” as “UL” requires for flammable gasses. This removes any potential for a static build-up and resulting arc.
- BROEN BALLOMAX® weld ends are A106 grade B seamless, A-105 Forged, or A 350 LF2 or equivalent material and marked in accordance to API-6D section 2.6 A

## II. QUALITY ASSURANCE AND CONTROL

### **The BROEN Quality Management System**

BROEN VALVE GROUP was originally certified according to EN 29001/ ISO 9001 on September 9, 1994. Audits are periodically performed to ensure certification validity.

BROEN VALVE Group's Quality Management System is now described by an electronic document, accessible to all relevant employees, continuously updated and improved, and used for both internal and external audit purposes.



## ISO 9001 Certificate



### BROEN A/S

Skovvej 30, 5610 Assens, Denmark

This is a multi-site certificate, additional site(s) are listed on the next page(s)  
Bureau Veritas Certification Holding SAS – UK Branch certifies that the Management System of the above organisation has been audited and found to be in accordance with the requirements of the management system standards detailed below

### ISO 9001:2015

Scope of certification

Development, manufacturing, engineering and delivery of valves to District Energy & Gas, Building Installations & Control, Industrial Installations & Control, & Control valve solutions to Marine, Power & Energy.

Original cycle start date:	10-07-1991
Expiry date of previous cycle:	NA
Certification / Recertification Audit date:	NA
Certification / Recertification cycle start date:	16-09-2021
Subject to the continued satisfactory operation of the organization's Management System, this certificate expires on:	15-09-2024

Certificate No.: **DK014631**    Version: **2**    Issue date: **03-02-2022**



0008

Certification Body Address: 5th Floor, 66 Prescott Street, London, E1 8HG, United Kingdom

Local Office: Bureau Veritas Certification Denmark A/S, Oldenborggade 25-31, 7000 Fredericia

Further clarifications regarding the scope and validity of this certificate, and the applicability of the management system requirements, please call: (+45) 77 311 000.





BUREAU  
VERITAS

Bureau Veritas Certification

## BROEN A/S

### ISO 9001:2015

Scope of certification

Site Name/Location	Site Address	Site Scope
BROEN A/S (Head Office)	Skovvej 30, 5610 Assens, Denmark	Development, manufacturing, engineering and delivery of valves to District Energy & Gas, Building Installations & Control, Industrial Installations & Control, & Control valve solutions to Marine, Power & Energy.
BROEN Clorius (Clorius Controls)	ul. Strefowa 19, pl-58-200 Dzierzoniow, Poland	Manufacturing, engineering, and delivery of control valve solutions to Marine, Power & Energy.  Manufacturing and assembly of valves to Building Installations & Control.
BROEN Inc. (USA)	6421 Calle Lozano Dr., 77041 Houston, USA	Development, manufacturing, engineering, delivery and service of valves actuators and controllers to District Energy & Gas, Building Installations & Control and Industrial Power & Energy
BROEN POLAND sp. z o.o. (Pleszycka)	ul. Pleszycka 10, pl-58-200 Dzierzoniow, Poland	Development, manufacturing, engineering and delivery of valves to District Energy & Gas, Building Installations & Control and Industrial Installations & Control.

Certificate No.: **DK014631**    Version: **2**    Issue date: **03-02-2022**

*Phil Absalonen*



0008

Certification Body Address: 5th Floor, 66 Prescott Street, London, E1 8HG, United Kingdom

Local Office: Bureau Veritas Certification Denmark A/S, Oldenborggade 25-31, 7000 Fredericia

Further clarifications regarding the scope and validity of this certificate, and the applicability of the management system requirements, please call: (+45) 77 311 000.



### III. ENGINEERING DETAILS

## Design and Engineering Data

<b>Labels</b>	Permanently stamped and affixed to each valve with traceable serial numbers
<b>Body</b>	ANSI 150 and ANSI 300 Standard Trunnion Mounted valves, are A-106 Carbon Steel, Forged Steel Ends of, A-105, S355 J2 or A 350 LF2 material or equal Paint Standard paint is a Non-Toxic water based prime BROEN can provide specialty coatings in house such as 3M 323, or Coal Tar Epoxy.
<b>Ball</b>	High strength Carbon Steel, ground to specific tolerances, Electro-nickel coated to requirements and heat treated.
<b>Stem</b>	X20Cr13 High strength steel, Electro-nickel coated to requirements and heat treated.
<b>Stem Bearings</b>	Anti-Static Grounded ( Zinc coated)
<b>Weld Ends</b>	A-106 Grade B seamless, machined per ANSI B16.25
<b>Seat Seals</b>	PTFE Carbonized Teflon <sup>™</sup>
<b>Stem Seals</b> <b>Lower FKM (Viton®)</b>	Upper Buna N
<b>Gear Operators</b>	Horizontal Gear with Hand-wheel or Vertical Gear with 2" DI nut. All gears are sized to optimize performance. Suitable for above ground or Direct Burial.
<b>Flanged Ends</b>	ASTM A 105 Forged Steel per ANSI B16.5
<b>Testing</b>	Certified API 6D Hydrostatic Shell Test and Seat Test. Certified Secondary Air Seat Test per Customer requirements.



## Design Features

### Design

The BALLOMAX® Standard Trunnion Mounted Ball Valve is an all welded construction and designed and built to attain maximum strength and minimum weight. It is a Trunnion Mounted design using the double block concept of active spring loaded seats on either side of the ball. A vent or drain in the Trunnion is provided to be able to test the integrity of sealing in the full open or full closed position, or to remove trash from the seats.

### Non-Lubricated

The BALLOMAX Standard Trunnion Mounted Ball Valve is designed to be maintenance free and not require lubrication. The seats are non-lubricated fluoroplastic PTFE + 20% carbon. The seats are spring loaded by piston and are retained circumferentially to minimize any effect of cold flow. A perimeter Buna N “O” ring acts as a secondary seal for extreme -20 degree F sealing.

### Body

The body is manufactured of either heavy walled seamed carbon steel pipe, Cast Steel Pipe, A-105 Forged Steel, or A350 LF2 material depending on Pressure, Media, and or Temperature. It is an all weld design to eliminate potential leakage from bolted together surfaces. The valve is suitable for both above ground and direct buried applications.

### Pipe Ends

The pipe ends are of A106 grade B pipe material, or A105 forged steel material, that is machined to industry standards wall thicknesses. At the customer’s request the ends can be counter bored to match piping.

### Stem Bearing

The stem bearings are zinc coated to insure electrical continuity and no static discharge build up occurs.

### Stem Sealing

The blowout proof Stem sealing is provided by the use of an Upper O-ring of Buna N, separated by a PTFE Washer, and a Lower O-ring of FKM (Viton®). We also provide a PTFE Friction washer/seal at the base of the stem bearing to minimize friction forces.

### Trunnion Mounted Ball Design

The sealing principal is that the trunnion supported ball surface mates with the piston spring loaded PTFE seats on both sides of the Ball creating a double blocking design. This is especially desirable in High Differential pressure applications to eliminate high torque in the operations of the valve. BALLOMAX Standard Trunnion Mounted valves come equipped with a Bleed / Drain port to vent the body of the valve to insure 100% open or closed position determination.

### ISO Mounting Plate

All Standard Trunnion Mounted Valves require Gear Operations. We offer both, Horizontal Gear or Vertical Gear Operators properly sized to optimize operations.

## **Welding**

The welding ends of the valve are ANSI B 16.25 prepared for API 1104 standard arc welding procedures and are of a length to allow for arc welding without any unusual precautions. Gas welding is not recommended. Gas welding may cause excessive heat to build up that exceeds 250 degrees at the sealing surfaces and can burn the seats. The valve should be welded in the Fully Open position, and precautions to protect the inside sealing surface area should be protected against weld splatter or weld beads in the sealing area.

## **Labeling**

Every BALLOMAX valve has a permanently affixed Label per API 6D code. It provides you with critical information permanently stamped to insure no misapplication of correct valve pressure rating is used for the application that it is intended.

## **Storage**

All BROEN BALLOMAX® Valves are shipped to you in the FULL OPEN position. You should always Store valves in their full open position to prevent damage to the balls.

Valves shipped to job sites should always be in the FULL OPEN position, with suitable factory provided end protection.

Gear Operators are factory set and should not be removed or adjusted before or during construction without consulting a factory representative.

## **Actuators**

Valves can be supplied with any type of actuator. Please provide all relevant actuator specs and controls requirements when requesting an automated valve package.

## Data Sheet

<b>Specifications Required:</b>	API-6D latest edition; MSS-SP-72; DOT 192 title 49; DOT 192-145
<b>Valve Size:</b>	4" – 24"
<b>Port:</b>	Full Port
<b>Usage:</b>	Steel Distribution and Compliance Pipeline, Bypass lines, Hot Tapping for Natural Gas Service.
<b>Location:</b>	Above Ground and Below grade direct burial.
<b>Maximum Operating Pressure:</b>	285 PSI (ANSI 150) and 740 PSI (ANSI 300)
<b>Maximum Field Test Pressures:</b>	(see API-6D Paragraph 3): 1.5 times MAOP with valve in full open position, 1.1 times MAOP with valve in full closed position.
<b>Pressure Class:</b>	ANSI 150 and ANSI 300
<b>Maximum Service Temperature:</b>	250° F
<b>Minimum Service Temperature:</b>	-20° F
<b>Service:</b>	Natural Gas or Propane
<b>Type of Valve:</b>	Ball Valve, Trunnion Mounted, Non-Lubricated, Quarter Turn with multi-turn Gear Operator.
<b>End Connections:</b>	Weld ends are A-106 Grade B Seamless pipe or equivalent, S355 J2, or A-105 Forged Steel (ANSI B16.25 Weld profile). Flanged Ends are ASTM A 105 Forged Steel Machined Flanges. Available in Weld End, Weld X Flange and Flange X Flange. All valves are built to ANSI length.
<b>Ball:</b>	Carbon Steel with Electro nickel coating plus heat treating per NACE.
<b>Stem and Trunnion:</b>	Carbon Steel with Electro nickel coating plus heat treating per NACE.
<b>Seat</b>	PTFE+ 20%C (±5%), G 453 material. 60 micron particle size, 40 micron carbon black filler

## Extract from Catalog

### WELD X WELD – 285 PSI – ANSI 150



Size	Catalog number	Port	Length	Wall	Weight
4"	4BMW285BFPTRSBHGS	4.00	12.00	0.237	*
6"	6BMW285BFPTRSBHGS	6.00	17.99	0.280	397
8"	8BMW285BFPTRSBHGS	7.87	20.51	0.322	320
10"	10BMW285BFPTRSBHGS	9.84	22.00	0.365	474
12"	12BMW285BFPTRSBHGS	11.81	25.00	0.375	1.198
16"	16BMW285BFPTRSBHGS	15.24	33.00	0.375	1.481
18"	18BMW285BFPTRSBHGS	17.00	36.00	0.375	3.197
20"	20BMW285BFPTRSBHGS	19.25	39.00	0.375	3.858
24"	24BMW285BFPTRSBHGS	23.27	45.00	0.375	6.283
30"	30BMW285BFPTRSBHGS	29.00	55.00	*	10.582
36"	36BMW285BFPTRSBHGS	34.50	68.00	*	18.739

\*Note: Information based on request

### FLANGE X FLANGE – 285 PSI – ANSI 150



Size	Catalog number	Port	Length	ANSI	Weight
4"	4BMF285BFPTRSBHGS	4.00	9.00	150	*
6"	6BMF285BFPTRSBHGS	6.00	15.50	150	397
8"	8BMF285BFPTRSBHGS	7.87	18.00	150	374
10"	10BMF285BFPTRSBHGS	9.84	21.00	150	532
12"	12BMF285BFPTRSBHGS	11.81	24.00	150	1.294
16"	16BMF285BFPTRSBHGS	15.24	30.00	150	1.612
18"	18BMF285BFPTRSBHGS	17.00	34.00	150	3.197
20"	20BMF285BFPTRSBHGS	19.25	36.00	150	3.858
24"	24BMF285BFPTRSBHGS	23.27	42.00	150	6.283
30"	30BMF285BFPTRSBHGS	29.00	51.00	150	10.582
36"	36BMF285BFPTRSBHGS	34.50	60.00	150	18.739

\*Note: Information based on request  
Weld x Flange available upon request

### OPTIONAL VERTICAL GEAR OPERATOR (VGS)





## WELD X WELD – 740 PSI – ANSI 300



Size	Catalog number	Port	Length	Wall	Weight
4"	4 BMW740BFPTRSBHGS	4.00	12.00	0.237	*
6"	6 BMW740BFPTRSBHGS	6.00	18.00	0.280	441
8"	8 BMW740BFPTRSBHGS	7.87	20.51	0.322	320
10"	10 BMW740BFPTRSBHGS	9.84	22.00	0.365	474
12"	12 BMW740BFPTRSBHGS	11.81	25.00	0.375	1,198
16"	16BMW740BFPTRSBHGS	15.24	33.00	0.375	1,481
18"	18BMW740BFPTRSBHGS	17.00	36.00	0.375	3,483
20"	20BMW740BFPTRSBHGS	19.25	39.00	0.375	4,299
24"	24BMW740BFPTRSBHGS	23.27	45.00	0.375	6,283
30"	30BMW740BFPTRSBHGS	29.00	55.00	*	12,125
36"	36BMW740BFPTRSBHGS	34.50	68.00	*	19,841

\*Note: Information based on request

## FLANGE X FLANGE – 740 PSI – ANSI 300



Size	Catalog number	Port	Length	ANSI	Weight
4"	4 BMF740BFPTRSBHGS	4.00	12.00	300	*
6"	6 BMF740BFPTRSBHGS	6.00	15.88	300	441
8"	8 BMF740BFPTRSBHGS	7.87	19.76	300	430
10"	10 BMF740BFPTRSBHGS	9.84	22.36	300	568
12"	12 BMF740BFPTRSBHGS	11.81	25.50	300	1,322
16"	16BMF740BFPTRSBHGS	15.24	33.00	300	1,814
18"	18BMF740BFPTRSBHGS	17.00	36.00	300	3,483
20"	20BMF740BFPTRSBHGS	19.25	39.00	300	4,299
24"	24BMF740BFPTRSBHGS	23.27	45.00	300	6,283
30"	30BMF740BFPTRSBHGS	29.00	55.00	300	12,125
36"	36BMF740BFPTRSBHGS	34.50	68.00	300	19,841

\*Note: Information based on request  
Weld x Flange available upon request

## OPTIONAL VERTICAL GEAR OPERATOR (VGS)



## HORIZONTAL INPUT

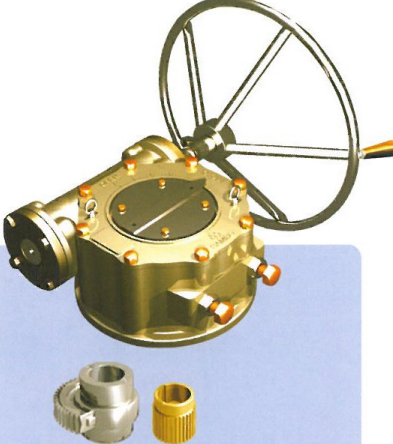

**FEATURE**

**Bushing Type**  
Splines permit accurate alignment of valve stem key

- All mounting bases conform to ISO 5210/1 Standards
- All castings are Ductile iron, Class 65-45-12  
Excellent strength and impact resistance
- Worm Gear material is available in two options
  - Ductile iron, Class 80-55-06
  - Aluminum bronze, B148-C95800
- Worm is 4140 Heat Treated Alloy Steel
- Removable splined Bushing to permit accurate positioning between gear drive and valve stem
- Options include hand wheels, chain wheels, etc

### M. O. V option

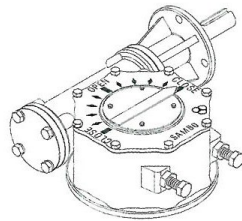

Worm Gear can be provided with Motor actuator Input flanges to accept standard ISO Mounting Base

### Locking Device option

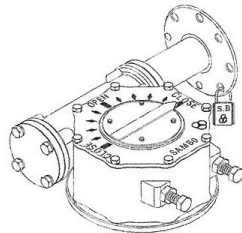

Input can be equipped with a Hand wheel locking Device for Manually operated units

### SELECTION CHART FOR MANUAL OPERATORS

MODEL	SIZE	GEAR RATIO	MAX. Stem Acceptance	Mounting option & Standard	MAX. Torque Capacity		WEIGHT Kg
					N · m	Ft · lbf	
SBWG-BF		32 : 1	20 (6x6)	F-07	310	229	4
SBWG-0		36 : 1	28 (8x7)	F-07, F-10	600	443	6
SBWG-00		38 : 1	36 (10x8)	F-10, F-12	1000	738	9
SBWG-01		42 : 1	46 (14x9)	F-12, F-14	1550	1143	13
SBWG-02		48 : 1	60 (18x11)	F-14, F-16	2400	1770	21
SBWG-03		52 : 1	75 (20x12)	F-16, (F-20)	4300	3172	30
SBWG-04		56 : 1	95 (25x14)	(F-20), F-25	7700	5680	62
SBWG-05		60 : 1	115 (32x18)	F-25, F-30	14800	10916	88
SBWG-06		64 : 1	140 (36x20)	F-30, F-35	26700	19693	162
SBWG-07		68 : 1	180 (45x25)	F-35, F-40	51100	37690	268
SBWG-08		58 : 1	225 (50x28)	F-40, F-48	106000	78182	510
SBWG-09		62 : 1	280 (63x32)	F-48, F-60	167000	123173	930
SBWG-10		64 : 1	320 (70x36)	F-60	250000	184390	1515
SBWG-11		68 : 1	360 (80x40)	F-60	370000	272897	2145
SBWG-12		72 : 1	400 (90x45)	F-60, (F-80)	540000	398283	3130



## SINGLE REDUCTION



### M, O, V option

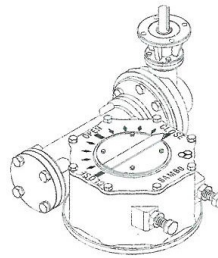

Worm Gear can be provided with Motor actuator Input flanges to accept standard ISO Mounting Base

### Square Nut option

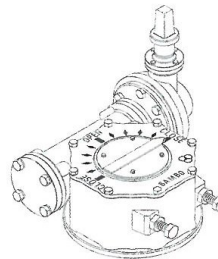

Should state that Optional Square nut can be provided on input shaft

### SELECTION CHART FOR MANUAL OPERATORS

MODEL	SIZE	GEAR RATIO	MAX. Stem Acceptance	Mounting option & Standard	MAX. Torque Capacity		WEIGHT Kg
					N · m	Ft lbf	
SBWG-00-2B		76 : 1	36 (10x8)	F-10, F-12	1000	738	15
SBWG-01-2B		84 : 1	46 (14x9)	F-12, F-14	1550	1143	19
SBWG-02-2B		120 : 1	60 (18x11)	F-14, F-16	2400	1770	29
SBWG-03-2B		130 : 1	75 (20x12)	F-16, (F-20)	4300	3172	38
SBWG-04-2B		182 : 1	95 (25x14)	(F-20), F-25	7700	5680	78
SBWG-05-2B		195 : 1	115 (32x18)	F-25, F-30	14800	10916	104
SBWG-06-2B		256 : 1	140 (36x20)	F-30, F-35	26700	19693	195
SBWG-07-2B		272 : 1	180 (45x25)	F-35, F-40	51100	37690	301
SBWG-08-2B		319 : 1	225 (50x28)	F-40, F-48	106000	78182	598
SBWG-09-2B		372 : 1	280 (63x32)	F-48, F-60	167000	123173	1048
SBWG-10-2B		416 : 1	320 (70x36)	F-60	250000	184390	1693
SBWG-11-2B		442 : 1	360 (80x40)	F-60	370000	272897	2323
SBWG-12-2B		504 : 1	400 (90x45)	F-60, (F-80)	540000	398283	3397

## SEALING OF THE STEM

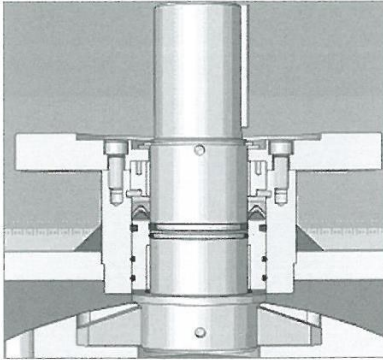

The sealing of the stems used in the valves manufactured by BROEN depends on the operating temperatures of the valve and the working medium for which the given valve is dedicated.

Front sealing is provided by a seal-washer made from PTFE + C, while the sealing on the stem's diameter is made depending on the operating temperature, i.e.:

- for temp.  $\leq 302F$  – sealing provided by o-rings or o-rings and PTFE
- for temp.  $> 302F$  – sealing from PTFE

In respect of the valves with fire safe protection the stem has additional sealing made from a graphite ring.

## STANDARD BALL SEALING

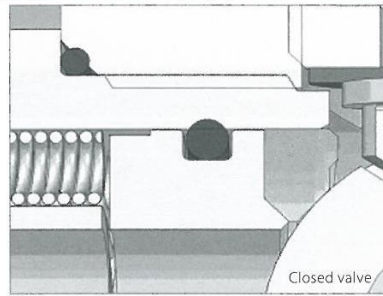
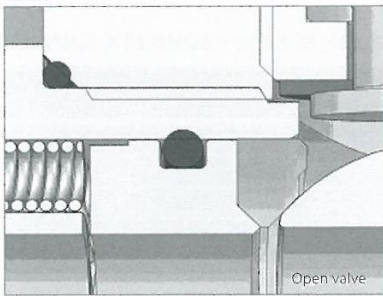

The tightness of the valve is ensured by the seals made from PTFE, PTFE + C or POM materials.

The material of the seal is selected depending on the applications, for which the valve is dedicated.

The standard sealing is applied to both the valves with the floating ball and with the trunnion mounted ball.

## DOUBLE PISTON EFFECT

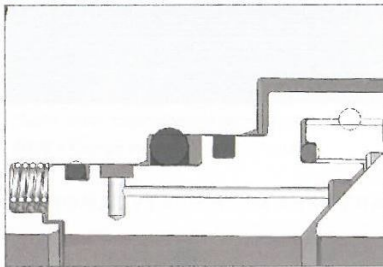

Both seals in the valves with the "Double Piston Effect" (DPE) actively participate in the internal sealing of the valve. In the case of any damage to one of the seals, the tightness of the valve is ensured by a second seal thanks to their special construction.

## IV. TESTING CODE AND COMPLIANCE

## Test Procedure According to API-6D Section 10 with ISO 5208 Rate A Acceptance Criteria

We hereby detail our test procedures according to API-6D section 10 with ISO 5208 rate A acceptance criteria.

**These tests are performed and certified prior to leaving our manufacturing facility. Each valve is documented and has a test certificate which is available upon request.**

No test procedure will be started until the valve is at room temperature.

All **BROEN BALLOMAX®** Valves are tested in accordance with the procedures described below.

Any additional customer specified test will be evaluated, performed and certified in accordance with provided written requirements. BROEN Inc. reserves the right to review same for additional charges.

### Hydrostatic Shell Test

1. The BROEN BALLOMAX® valve is placed in the testing bench.
2. The valve is opened half way and water (or other test media) at ambient temperature is pumped into it.  
Pressure is built up to 1.5 times MAOP.
3. At the test pressure the operator is observing the valve in the specified testing time.

Testing time for 4" and smaller:	2 Minutes
Testing time for 6" thru 10":	5 Minutes
Testing time for 12" thru 18":	15 Minutes
Testing time for 20" and larger:	30 Minutes

4. No visible leakage is permitted: the valve is rejected if any leakage is detected.

### Hydrostatic Seat Test

1. The BROEN BALLOMAX® valve is placed in the testing bench.
2. The valve is opened half way and water (or other test media) at ambient temperature is pumped into it. Pressure is built up to 1.1 times MAOP.
3. The valve is closed, and the test machine valve is closed between the valve and the machine pump. A manometer is observed while one side of the valve is drained and vented. After 15 seconds, the pressure is registered, and with any pressure loss the valve is rejected. The specified testing time is as follows:

Testing time 4" and smaller:	2 minutes
Testing time 6" to 18":	5 Minutes
Testing time 20" and larger:	10 minutes

- Paragraph 3 is now repeated for the other connection end of the valve.
- The test media is evacuated from the valve.

## Supplementary Air Seat Test According to API 6D L.19 Type I and II (ISO 5208 Rate A)

### Low-pressure Gas Seat Testing-Type I

- The **BROEN BALLOMAX**<sup>®</sup> valve is placed in the testing bench.
- The valve is opened half way, the closure member and leakage measurement connection port shall be purged with air, and air at ambient temperature is pumped into it at 10 psi.
- The valve is closed, and the test machine valve is closed between the valve and the machine pump. A manometer is observed while one side of the valve is drained and vented. After a period of 2 minutes of constant pressure, the stabilization period begins. The stabilization period can be extended in case stabilization is not achieved. The stabilization period is as follows:

Stabilization time 4" and smaller:	5 minutes
Stabilization time 6" to 10":	10 Minutes
Stabilization time 12" to 18":	15 Minutes
Stabilization time 20" and larger:	15 minutes

- Following stabilization, the test begins. The pressure is registered, and with any pressure loss the valve is rejected. The specified testing time is as follows:

Testing time 4" and smaller:	2 minutes
Testing time 6" to 18":	5 Minutes
Testing time 20" and larger:	10 minutes

- Paragraphs 3 & 4 are now repeated for the other connection end of the valve.
- The test media is evacuated from the valve.

The test benches are calibrated four times per year according to procedures described in the quality control system of BROEN A/S.

### Low-pressure Gas Seat Testing-Type II

- The **BROEN BALLOMAX**<sup>®</sup> valve is placed in the testing bench.
- The valve is opened half way, the closure member and leakage measurement connection port shall be purged with air, and air at ambient temperature is pumped into it at 90 psi.
- The valve is closed, and the test machine valve is closed between the valve and the machine pump. A manometer is observed while one side of the valve is drained and vented. Pressure shall be identified

as stabilized when the rate of change is no more than 5% of the test pressure within 5 minutes. (87.75-92.25 psi range).

4. Following stabilization, the test begins. The pressure is registered, and with any pressure loss the valve is rejected. The specified testing time is as follows:

Testing time 4" and smaller:	2 minutes
Testing time 6" to 18":	5 Minutes
Testing time 20" and larger:	10 minutes

5. Paragraphs 3 & 4 are now repeated for the other connection end of the valve.
6. The test media is evacuated from the valve.

The test benches are calibrated four times per year according to procedures described in the quality control system of BROEN A/S.

## Valve Documentation

All BROEN Standard Trunnion valves are supplied with a test certificate related to the pressure test (hydrotest and air test).

Additional MTRs (including chemical compositions and mechanical properties of the materials, etc.) are available upon request.



## Test Certificate Example

<b>Test Certificate</b>		<b>BROEN</b> <small>VALVE TECHNOLOGIES</small>	
<b>Customer:</b> [Customer Name]	<b>Order No.:</b> [Order Number]		
<b>Serial No.:</b> [7 digits unique number]			
<b>Test article:</b> Ball valve <b>Port size:</b> Full Port <b>End connections:</b> Welding - Welding <b>Size:</b> 10"			
<b>MAOP:</b> 285 PSI		<b>Quantity:</b> 1 <b>Drawing no.:</b> 3/C250WW883	
<b>Materials</b>			
<b>Valve Component</b> <b>Material Type, Material Grade or P-number per ASME BPVC IX</b>			
<b>Welding end:</b> Carbon steel, P1 group per ASME BPVC IX			
<b>Welding end:</b> Carbon steel, P1 group per ASME BPVC IX			
<b>Valve body:</b> Carbon steel, P1 group per ASME BPVC IX			
<b>Stem:</b> Stainless steel, AISI 420			
<b>Ball:</b> Low Temp Carbon steel, A350LF2 + ENP			
<b>Seat:</b> PTFE			
<b>Operation Means:</b> Gear Operator            2inch square nut <b>Gear Orientation:</b> Vertical <b># of Turns:</b> 31.5			
<b>Pressure Test</b>			
Testing ball valve according to API specification 6D, Sec.10 25th Edition, November 2021			
<b>Hydrostatic Test</b>			
	<b>Test Pressure (Psig)</b>	<b>Test Time (Minutes)</b>	<b>Test Result (Pass/Fail)</b>
Section 10.3, Shell Test	430	5	Pass: No visible leakage
Section 10.4, Seat Test - Seat A	315	5	Pass: No visible leakage
Section 10.4, Seat Test - Seat B	315	5	Pass: No visible leakage
<b>Supplementary Test according to API 6D, Annex L</b>			
<b>Low-Pressure Gas Seat Test With Air</b>			
Acceptable Criteria: ISO 5208, Rate A, No Visible Leakage.			
	<b>Test Pressure (Psig)</b>	<b>Test Time (Minutes)</b>	<b>Test Result (Pass/Fail)</b>
- L.19.1 Type I - Seat A	10	5	Pass: No visible leakage
- L.19.1 Type I - Seat B	10	5	Pass: No visible leakage
- L.19.2 Type II - Seat A	90	5	Pass: No visible leakage
- L.19.2 Type II - Seat B	90	5	Pass: No visible leakage
<b>Label:</b> STD			
<b>Houston, TX</b>		<b>Date:</b> 4/24/2023 <b>Inspector:</b> Gustavo Perez	
BROEN, Inc. 6421 Lozano Dr. Houston TX, 77041		<b>Telephone:</b> (713) 300-0480 <b>Email:</b> <a href="mailto:info@broen.com">info@broen.com</a>	

## V. STANDARD VALVE PROCEDURES

## Valve Preservation and Storage

The internal surfaces of the valve are protected against corrosion with a protection film. This protects the valve for a period of 6 months.

We recommend to store the valve on a flat surface in a dry, clean area, protected against weather conditions and corrosive agents.

The valves should always be stored in their full open position to prevent damage to the balls.

The valves are supplied with end caps to protect the beveled ends or the flange surface. These protection caps are to be kept until valve installation.

Valves are shipped in a durable environmentally-friendly packaging. Disposal of valve packaging is under responsibility of BROEN's customers.

## Valve Handling, Transportation, and Shipment

All BROEN BALLOMAX® Valves are to be shipped in the FULL OPEN position.

Gear Operators are factory set and should not be removed or adjusted before or during construction without consulting a factory representative.

Valves are to be handled with extreme caution.

Valves without lifting lugs are to be lifted as shown in the following illustration:

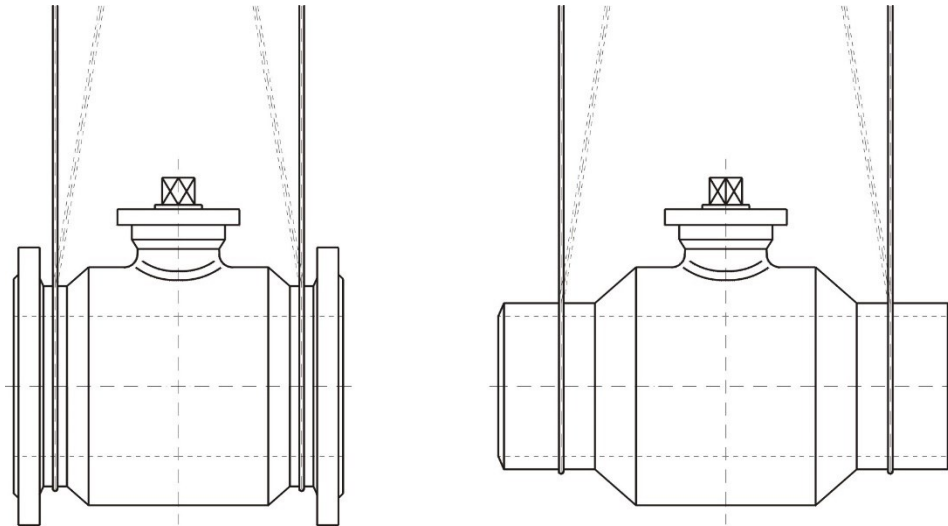

Valves with lifting lugs are to be lifted as shown in the following illustrations:

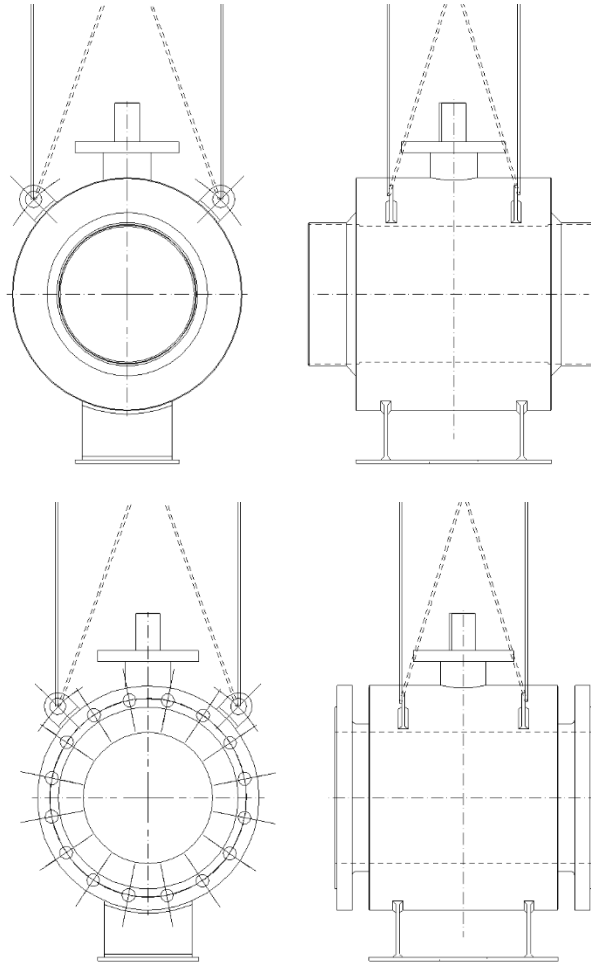

## Standard Installation Procedures

Keep the Standard Trunnion Mounted Ball Valve in the Fully OPEN position During Installation. The Full Open position best protects the soft seats from potential high heat and weld splatter. We suggest protecting the area where the ball and seat seals join to prevent weld splatter or weld beads attaching and possibly scratching the ball.

Do Not leave the Valve in any Partial Open or Closed Position. This allows for the edge of the ball to rest on the soft PTFE seat which may temporarily cause an indentation in the soft seat until it has time to cold flow back into proper position. It also exposes the seats to heat and potential weld splatter.

A closed Ball Valve leave open the surface of the Ball Valve that can be damaged by weld splatter. Especially important when welding in the vertical position.

The Standard Trunnion Mounted Ball Valve is a bi-directional valve.

On Gear Operated Valves it is advisable to fully cycle operator before installation, while observing operation and the proper set points of the travel stops in Fully Open and Fully Closed positions. The travel stops are measured and set at the factory and marked.

Testing of welds can be performed by Hydrostatic testing or Nitrogen testing as is normal construction practice. The valve has already undergone API Hydrostatic Shell Testing but to check your welds review the testing methods in the Testing of Field Welds Section.

**Installation Position:** The BROEN BALLOMAX Standard Trunnion Mounted Ball Valve operates in any position, with either vertical or horizontal stem, as shown in the pictures below.

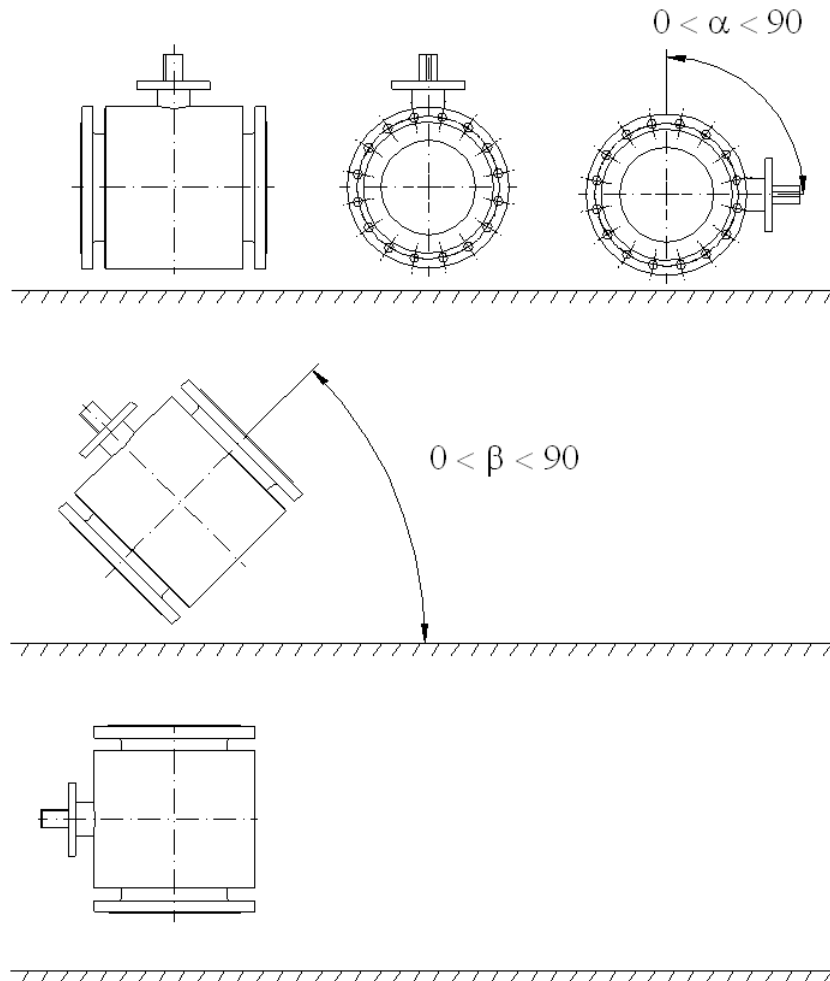

Valves with stem extensions (high end extensions) must be installed with vertical stem only. Please note that stem extensions must not be exposed to bending forces or torques.

## Field Welding:

The welding ends of the valve are ANSI B 16.25 prepared for API 1104 standard arc welding procedures and are of a length to allow for arc welding without any unusual precautions. Gas welding is not recommended because it may cause excessive heat to build up that can burn the seats.

The valve should be welded in the Fully Open position, and the inside sealing surface area should be protected against weld spatter or weld beads in the sealing area.

For valves with weld ends, please follow the proper WPS. Monitor the valve body temperature while welding, at a distance X from the welding point. Do not exceed 120°C (248°F).

Valve size	X [mm/inch]
Up to 4"	50/2
6" and above	100/4

Pups: Valves with pups prepared in a valve shop prior to installation may be preferable in some applications. The pups allow for a longer distance between the weld location and the soft seats, decreasing the likelihood of damage. The pups allow the site welds to weld the same pipe as the rest of the pipeline, following the same welding procedure. The increased length can also help with alignment during installation.

On Gear Operated Valves it is advisable to fully cycle operator before installation, while observing operation and the proper set points of the travel stops in Fully Open and Fully Closed positions. The travel stops are measured and set at the factory and marked.

Testing of welds can be performed by Hydrostatic testing or Nitrogen testing as is normal construction practice. The valve has already undergone API Hydrostatic Shell Testing at the factory. To check the integrity of your welds, review the dedicated section "Testing of Field Welds".

## Testing of Field Welds

After welding, you may desire to test the welds hydrostatically or with nitrogen as is common practice in the Industry. Below are our procedures.

### a) Hydro Testing:

The valve has already undergone API certification at the factory and the test certificates if requested from the factory show the results of these tests. Never Test Against a Closed Ball Valve.

Field Hydrostatic testing should be as follows:

1. Fill the Pipeline with clean water, with the Valves in the FULLY OPEN position. Filling the pipeline with valves in the partial open position allows for rust scale and trash to enter the valve body.
2. Once filled, you can move the ball to ½ open position to allow the cavity of the valve to fill with water.

3. Pressurize the line and perform test.
4. Valves should be returned to Fully Open position before draining the Pipeline. This prevents rust scale and trash entering the valve body and building up in the soft seat area which may cause damage to seats.
5. Upon draining the Pipeline, it is necessary to drain the valves using the drain in the bottom of the trunnion to remove all water from the cavity of the valve.
6. Note: if the valve has been left in the partial open position for an extended period, the valve should be exercised several times and left in the Full Open or Fully Closed position for the Soft Seat material to cold flow back into position for 100% shut off.
7. It is important not to use this newly installed valve for a blowdown valve or throttling valve. A sacrificial valve should be installed downstream for blowing down your line.

#### b) Nitrogen Testing

We understand that Nitrogen Testing is a common construction practice. This testing should be performed under careful practices that include heating of the nitrogen to prevent the valves plasticized components from freezing and damage.

This valve is for Natural Gas Service. We do not perform Nitrogen testing on our valves. We test to API-6D standards. When testing with Nitrogen you must respect that you are testing your welds, not the sealing ability of the soft seated valve. The molecules of Nitrogen, which are dry and very cold, are many times smaller than that of Natural Gas, which has natural lubricating properties. If your Nitrogen is not preheated, you can destroy the seats of the valve. Never test with unheated Nitrogen with the valve in the partial open position and never where the test media is lower than -40F.

Be sure to thoroughly drain and dry the valve after test.



## Hot Tapping

BALLOMAX® Standard Trunnion Mounted Weld X Flange Valves are Full Port Open Valves and are suitable for Hot Tapping Operations. Always Tap through the valve in the Fully Open position. It is very important to remove all metal chips from the Tapping Operation prior to closing the Valve. This is a soft seated valve and the seats can be damaged from the metal tapping chips.

If pressure testing the valve after installation but before the coupon is cut, ensure that the test pressure does not exceed the current operating pressure of the line to prevent damage to the pipeline.

We recommend you refer to the Tapping Equipment Manufacturers procedure for the Tapping operation and procedure. Ensure the proper drilling tool is selected based on the port size, valve nest dimension, and overall length of the valve. As a general rule, the cutter size should be at least 0.5" smaller than the valve port size.

## Valve Operations

Your BROEN BALLOMAX® Standard Trunnion Mounted Ball Valve is designed for On / Off service. The valve should never be used as a Throttling Valve or Blowdown Valve.

Typical BROEN BALLOMAX® Standard Trunnion Mounted Ball Valves 3" and below use a lock plate and 2" nut. The nut has an extrusion that serves as the indicator showing the valve's position. The valve is open when the extrusion is in-line with the direction of the pipeline. If the extrusion is perpendicular to the pipeline direction, the valve is closed. The lock plate includes mechanical stops to ensure the fully closed/open position is achieved.

Typical BROEN BALLOMAX® Standard Trunnion Mounted Ball Valves 4" and above are Gear Operated Valves and have a Rotating position indicator. The indicator clearly shows Open and Closed positions and provides you visually the travel direction of the valve stem.

The valve OPENS counter-clockwise and CLOSES clockwise. The valve is a quarter-turn operation. The Gear Operator is multi-turn to slowly move the ball into the desired position. The number of turns is marked on the Gear.

The Gear Operator has positive stops incorporated into the unit for full open and full closed positions. The positions are set at the factory and determined by measurements based on the ball position. If you need to reposition in the field, please call your representative on the procedure.

## Valve Maintenance

BROEN BALLOMAX® Standard Trunnion Mounted Valves are maintenance-free Ball Valves. The only maintenance required is to operate the valve to clean the seats if you don't get a full shut off. It is recommended to operate the valve at least once every calendar to verify the ball is not stuck.

## Troubleshooting

BROEN BALLOMAX Standard Trunnion Mounted Ball Valves are designed such that there are very few problems that can be experienced. If you do have issues, please call your Representative or our Office for assistance.

Few remarks:

- If the seats are SPE (self-relieving), allow for any over-pressure within the body cavity time to be released before checking for leaks.
- If the valve is not sealing, make sure that the valve is in fully closed position.