

# BROEN

VALVE TECHNOLOGIES

## BROEN BALLOMAX® FLOATING BALL VALVES



**BROEN**  
BALLOMAX®

*Designed to last*



## Who we are

Founded in 1948 in Denmark, BROEN today is a global valve manufacturing group of companies. For more than 75 years, BROEN has been the leader in the development and production of valve technology for water, air and gas. Our goal is to build long-lasting and trust-based partnerships with our valued Customers, through the local presence of our companies and our capillary sales and service network.

BROEN employs more than 600 employees in five manufacturing facilities worldwide producing more than three million valves per year. ISO 9001 certified since 2001, BROEN is committed to ensuring our Customers receive high-quality products that exceed expectations.

BROEN has a strong focus on innovation, continuously improving our product range to offer state-of-the-art solutions and technologies, including BROEN BALLOMAX®, the industries' best ball valves for natural gas service.

### THE BROEN BALLOMAX® VALVES

Large and small, high or low pressure, BROEN always has the valve you need.



FLOATING BALL VALVES



TRUNNION AND  
API-6D MONOGRAMMED  
BALL VALVES



POLYETHYLENE (PE)  
VALVES

**BROEN**  
BALLOMAX® *Designed to last*



**BROEN**  
VALVE TECHNOLOGIES



## Floating ball valves

BROEN BALLOMAX®, floating ball valves are designed specifically for natural gas distribution systems.

BROEN BALLOMAX® floating ball valves are the best choice when it comes to steel ball valves for natural gas distribution systems.

All our floating ball valves feature an all-welded body with no potential leak path. Our valves are long lasting and maintenance-free. Standard ball and stem are stainless steel.

Maximum safety is granted by the anti-blow out stem design. Moreover, all valves are equipped with “safety grounded stem” that removes any risk of static build up and resulting arc.

The sealing is granted by carbon filled PTFE seats for zero-leakage. To prevent stem leaks all valves are supplied with a redundant stem sealing system.

Each valve features a unique serial number permanently stamped on the nameplate, allowing for full traceability.

Valves can accommodate a standard barrel lock or standard pad locks.

All valves are hydrostatically tested per API-6D: shell test and seat test. Additional low-pressure air test is performed to ensure tight sealing performance. Other tests available at Customer’s request. Test certificates are available for each valve.

Valves are equipped with POWERSTOPS™ preventing valve over-torque.

Valves 2” to 8” are tested per API 641 for fugitive emissions.

### **BROEN offers virtually endless configurations and customizations to meet all your needs:**

- Pressure rating (MOP): 285 PSI, 500 PSI, 740 PSI
- Port size: Regular and Full port
- Ball type: Concave and Straight
- End connections: any option. Weld ends are A106 Gr. B. Flanges are ANSI B16.5 A105 Gr. B.
- Operators: all operators available. Valve actuators and gear operators are also available.

## Four different styles:

- Pipeline style: the BROEN best-seller with endless configurations to fit most requirements.
- Premium style: high-end valve made with extra-strong forged components Short-pattern design is ideal for metering and regulating stations.
- Utility style: Cost-effective short pattern flanged end ball valve. Ideal to replace plug and iron body valves.
- NextGen style: the most innovative BROEN Full Port ball valve, integrating a vanced technology to enhance performance, sustainability, and traceability.

Valve modifications available at our shop in Houston, Texas include:

- Specialty coatings
- Stem extensions
- Valves with special length and extended pups
- Valves with gears, actuators, limit switches, etc.

Please contact us for any valve needs you may have.

## Catalog Numbering System

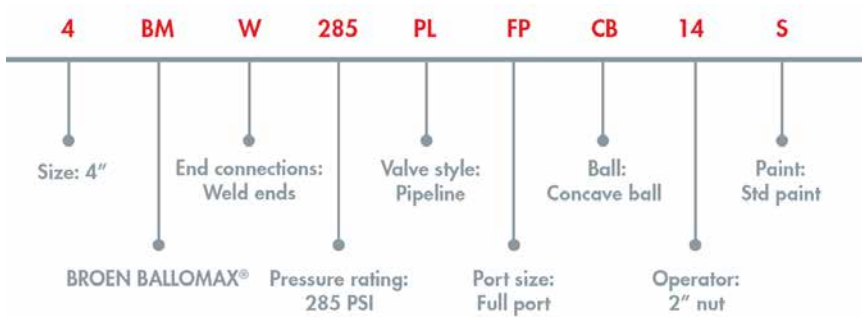

1. Size [inch]
2. BM: BROEN BALLOMAX®
3. End Configuration
  - W: Weld end
  - F: Flange end
  - WF: Weld x Flange
  - HT: Hot Tap
  - FT: Female thread end
  - WM: Weld x MPT thread

4. Pressure rating [PSI]
  - 285, 500, 740

5. Valve style
  - PL: Pipeline
  - PR: Premium
  - UV: Utility
  - NG: NextGen

6. Port
  - RP: Regular port
  - FP: Full port

7. Ball
  - CB: Concave ball
  - SB: Straight ball

8. Operator
  - 25: Curb nut
  - 14: 2" nut
  - HG: Horizontal gear
  - VG: Vertical gear

9. Paint
  - S: Standard water-based primer
  - 3M: 3M 323
  - B: Coal tar enamel



PIPELINE



PREMIUM



UTILITY



NextGen

## Components and Materials

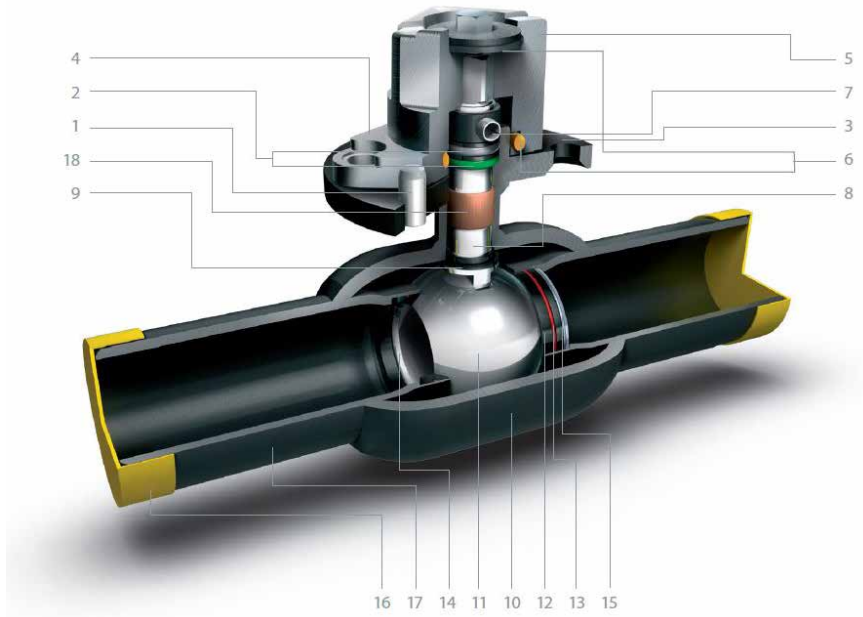

1. Powerstop (heat treated steel)
2. Stem seals (Viton Buna N and NBR)
3. Lock wing flange
4. Stainless steel stamped label
5. 2" square nut w/lock wing
6. Weather seal (Buna N gasket)
7. Steel travel stop pin
8. Stainless steel stem
9. Body stem friction washer
10. Carbon steel pipe body
11. Stainless steel ball
12. Seat ring (Teflon/PTFE)
13. Seat o-ring (Buna N o-rings)
14. Seat support ring
15. Stainless steel Belleville® spring
16. Protective end cap
17. Carbon steel (A 106 Gr. B) end connections
18. Stem bearing (zinc coated)

## Seat Specification



### Seat Quality Features

- Does not absorb water and does not expand
- Chemical resistant
- High friction characteristics
- Good temperature stability
- Tested and approved up to 482°F

### Seat Specification

The base material: PTFE powder

Type of material: G453

Particle size: 60 micron part

Size of filler: 40 micron

Type of filler: Carbon

Mix: PTFE +20% carbon

tolerance of content: ±5%

## Pipeline

### The BROEN best-seller with endless configurations to fit most requirements.

Fully welded, carbon steel, regular port floating ball valves, designed specifically for natural gas.

Manufactured from the same pipe material as your pipeline, they can be used in below ground or above ground applications.

#### These valves feature:

- Stainless steel balls and stem standard
- Quarter-turn operations
- Locking plate with POWERSTOPS™ 600 ft/lbs
- Seats of 25% carbonized PTFE (Teflon™) (G-453) rated to -20°F
- Zinc coated stem bearings
- Tested per API-6D requirements
- Serial numbered for full traceability

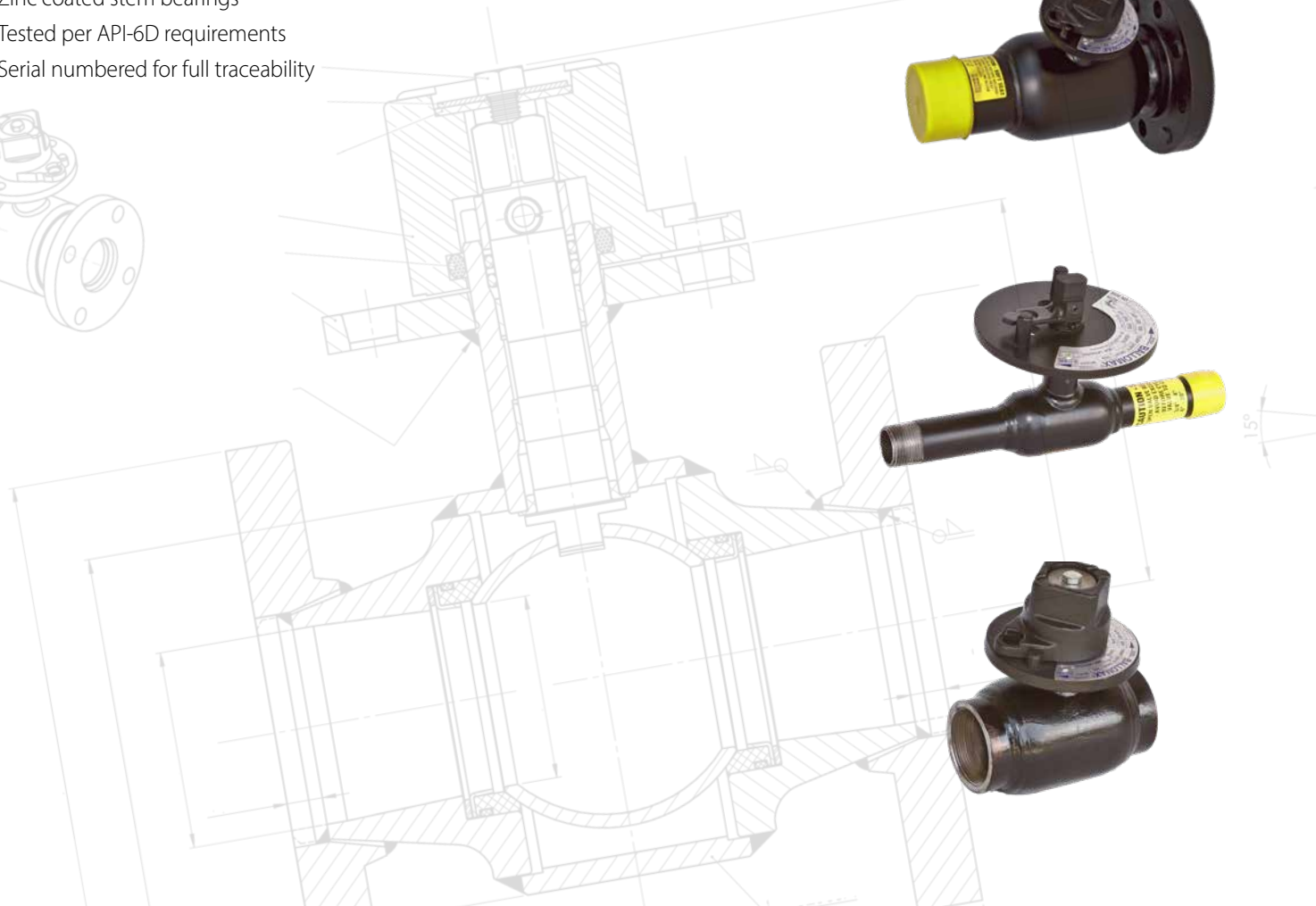
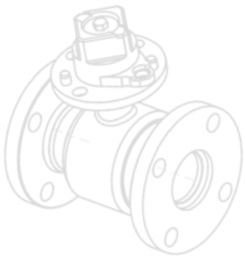

## Pipeline – Regular port

WELD X WELD – 285 PSI – ANSI 150					
Size	Catalog number	Port	Length	Wall	Weight
3/4" <sup>(1)</sup>	3/4 BMW 285 PLRP SB 25S	0.59	9.02	0.113	3
3/4"	3/4 BMW 285 PLRP SB 14S	0.59	9.02	0.113	5
1" <sup>(1)</sup>	1 BMW 285 PLRP SB 25S	0.79	9.06	0.133	4
1"	1 BMW 285 PLRP SB 14S	0.79	9.06	0.133	6
1-1/4"	5/4 BMW 285 PLRP SB 14S	1.00	10.24	0.140	7
2"	2 BMW 285 PLRP CB 14S	1.54	11.81	0.154	10
3"	3 BMW 285 PLRP CB 14S	2.48	14.60	0.216	18
4"	4 BMW 285 PLRP CB 14S	3.07	15.35	0.237	25
6"	6 BMW 285 PLRP CB 14S	4.90	15.35	0.280	56
8" <sup>(2)</sup>	8 BMW 285 PLRP CB 14S	5.75	15.35	0.322	131
8" <sup>(3)</sup>	8 BMW 285 PLRP CB HGS	5.75	15.35	0.322	161

WELD X WELD – 740 PSI – ANSI 300					
Size	Catalog number	Port	Length	Wall	Weight
3/4"	3/4 BMW 740 PLRP SB 25S	0.59	9.02	0.113	3
3/4"	3/4 BMW 740 PLRP SB 14S	0.59	9.02	0.113	5
1"	1 BMW 740 PLRP SB 25S	0.79	9.06	0.133	4
1"	1 BMW 740 PLRP SB 14S	0.79	9.06	0.133	6
1-1/4"	5/4 BMW 740 PLRP SB 14S	1.00	10.24	0.140	8
2"	2 BMW 740 PLRP CB 14S	1.54	11.81	0.154	13
3"	3 BMW 740 PLRP CB 14S	2.48	14.57	0.216	25
4"	4 BMW 740 PLRP CB 14S	3.07	15.35	0.237	35
6"	6 BMW 740 PLRP CB 14S	4.90	15.35	0.280	70
8" <sup>(2)</sup>	8 BMW 740 PLRP CB 14S	5.75	15.40	0.322	131
8" <sup>(3)</sup>	8 BMW 740 PLRP CB HGS	5.75	15.40	0.322	161

WELD X FLANGE – 285 PSI – ANSI 150					
Size	Catalog number	Port	Length	Wall	Weight
2"	2 BMWF 285 PLRP CB 14S	1.54	9.50	0.154	16
3"	3 BMWF 285 PLRP CB 14S	2.48	12.20	0.216	26
4"	4 BMWF 285 PLRP CB 14S	3.07	13.11	0.237	35
6"	6 BMWF 285 PLRP CB 14S	4.90	13.68	0.280	77
8" <sup>(2)</sup>	8 BMWF 285 PLRP CB 14S	5.75	15.90	0.322	140
8" <sup>(3)</sup>	8 BMWF 285 PLRP CB HGS	5.75	15.90	0.322	170

WELD X FLANGE – 740 PSI – ANSI 300					
Size	Catalog number	Port	Length	Wall	Weight
2"	2 BMWF 740 PLRP CB 14S	1.54	10.16	0.154	19
3"	3 BMWF 740 PLRP CB 14S	2.48	12.85	0.216	38
4"	4 BMWF 740 PLRP CB 14S	3.07	13.68	0.237	56
6"	6 BMWF 740 PLRP CB 14S	4.90	15.61	0.280	104
8" <sup>(2)</sup>	8 BMWF 740 PLRP CB 14S	5.75	15.90	0.322	189
8" <sup>(3)</sup>	8 BMWF 740 PLRP CB HGS	5.75	15.90	0.322	217

FLANGE X FLANGE – 285 PSI – ANSI 150					
Size	Catalog number	Port	Length	ANSI	Weight
2"	2 BMF 285 PLRP CB 14S	1.54	7.00	150	18
3"	3 BMF 285 PLRP CB 14S	2.48	8.00	150	31
4"	4 BMF 285 PLRP CB 14S	3.07	9.00	150	43
6"	6 BMF 285 PLRP CB 14S	4.90	10.50	150	81
8" <sup>(2)</sup>	8 BMF 285 PLRP CB 14S	5.75	11.50	150	158
8" <sup>(3)</sup>	8 BMF 285 PLRP CB HGS	5.75	11.50	150	188

FLANGE X FLANGE – 740 PSI – ANSI 300					
Size	Catalog number	Port	Length	ANSI	Weight
2"	2 BMF 740 PLRP CB 14S	1.54	8.50	300	25
3"	3 BMF 740 PLRP CB 14S	2.48	11.13	300	50
4"	4 BMF 740 PLRP CB 14S	3.07	12.00	300	75
6"	6 BMF 740 PLRP CB 14S	4.90	15.87	300	139
8" <sup>(2)</sup>	8 BMF 740 PLRP CB 14S	5.75	16.50	300	247
8" <sup>(3)</sup>	8 BMF 740 PLRP CB HGS	5.75	16.50	300	277

Dimensions listed in inch and pound.

Weld x Flange option available upon request.

<sup>(1)</sup> curb nut.

<sup>(2)</sup> w/nut.

<sup>(3)</sup> Standard with horizontal gear operator.

## Pipeline – Full Port Concave ball

WELD X WELD – 285 PSI – ANSI 150					
Size	Catalog number	Port	Length	Wall	Weight
2"	2 BMW 285 PLFP CB 14S	1.93	11.81	0.154	13
4"	4 BMW 285 PLFP CB 14S	3.86	15.35	0.237	35
6"	6 BMW 285 PLFP CB 14S	5.75	15.88	0.280	110

WELD X FLANGE – 285 PSI – ANSI 150					
Size	Catalog number	Port	Length	Wall	Weight
2"	2 BMWF 285 PLFP CB 14S	1.93	10.16	0.154	17
4"	4 BMWF 285 PLFP CB 14S	3.86	13.10	0.237	44
6"	6 BMWF 285 PLFP CB 14S	5.75	15.88	0.280	120

FLANGE X FLANGE – 285 PSI – ANSI 150					
Size	Catalog number	Port	Length	ANSI	Weight
2"	2 BMF 285 PLFP CB 14S	1.93	8.50	150	22
4"	4 BMF 285 PLFP CB 14S	3.86	12.00	150	57
6"	6 BMF 285 PLFP CB 14S	5.75	15.88	150	130

WELD X WELD – 740 PSI – ANSI 300					
Size	Catalog number	Port	Length	Wall	Weight
2"	2 BMW 740 PLFP CB 14S	1.93	11.81	0.154	13
4"	4 BMW 740 PLFP CB 14S	3.86	15.35	0.237	35
6"	6 BMW 740 PLFP CB 14S	5.75	15.88	0.280	110

WELD X FLANGE – 740 PSI – ANSI 300					
Size	Catalog number	Port	Length	Wall	Weight
2"	2 BMWF 740 PLFP CB 14S	1.93	10.16	0.154	19
4"	4 BMWF 740 PLFP CB 14S	3.86	13.10	0.237	55
6"	6 BMWF 740 PLFP CB 14S	5.75	15.88	0.280	147

FLANGE X FLANGE – 740 PSI – ANSI 300					
Size	Catalog number	Port	Length	ANSI	Weight
2"	2 BMF 740 PLFP CB 14S	1.93	8.50	300	26
4"	4 BMF 740 PLFP CB 14S	3.86	12.00	300	75
6"	6 BMF 740 PLFP CB 14S	5.75	15.88	300	180

Dimensions listed in inch and pound.

## Pipeline – Full Port Straight ball

WELD X WELD – 285 PSI – ANSI 150					
Size	Catalog number	Port	Length	Wall	Weight
3/4"	3/4 BMW 285 PLFP SB 14S	0.79	9.06	0.113	5
1"	1 BMW 285 PLFP SB 14S	0.98	9.06	0.133	6
2"	2 BMW 285 PLFP SB 14S	1.93	11.81	0.154	14
4"	4 BMW 285 PLFP SB 14S	3.86	15.35	0.237	37
6"	6 BMW 285 PLFP SB 14S	5.75	15.88	0.280	117

WELD X FLANGE – 285 PSI – ANSI 150					
Size	Catalog number	Port	Length	Wall	Weight
2"	2 BMWF 285 PLFP SB 14S	1.93	10.16	0.154	19
4"	4 BMWF 285 PLFP SB 14S	3.86	13.10	0.237	47
6"	6 BMWF 285 PLFP SB 14S	5.75	15.88	0.280	130

FLANGE X FLANGE – 285 PSI – ANSI 150					
Size	Catalog number	Port	Length	ANSI	Weight
2"	2 BMF 285 PLFP SB 14S	1.93	8.50	150	24
4"	4 BMF 285 PLFP SB 14S	3.86	12.00	150	62
6"	6 BMF 285 PLFP SB 14S	5.75	15.88	150	150

WELD X WELD – 740 PSI – ANSI 300					
Size	Catalog number	Port	Length	Wall	Weight
3/4"	3/4 BMW 740 PLFP SB 14S	0.79	9.06	0.113	5
1"	1 BMW 740 PLFP SB 14S	0.98	9.06	0.133	6
2"	2 BMW 740 PLFP SB 14S	1.93	11.81	0.154	14
4"	4 BMW 740 PLFP SB 14S	3.86	15.35	0.237	37
6"	6 BMW 740 PLFP SB 14S	5.75	15.88	0.280	117

WELD X FLANGE – 740 PSI – ANSI 300					
Size	Catalog number	Port	Length	Wall	Weight
2"	2 BMWF 740 PLFP SB 14S	1.93	10.16	0.154	21
4"	4 BMWF 740 PLFP SB 14S	3.86	13.10	0.237	58
6"	6 BMWF 740 PLFP SB 14S	5.75	15.88	0.280	155

FLANGE X FLANGE – 740 PSI – ANSI 300					
Size	Catalog number	Port	Length	ANSI	Weight
2"	2 BMF 740 PLFP SB 14S	1.93	8.50	300	28
4"	4 BMF 740 PLFP SB 14S	3.86	12.00	300	79
6"	6 BMF 740 PLFP SB 14S	5.75	15.88	300	192

## Pipeline – Female Threaded End



VALVE WITH 2" OPERATING NUT

## Pipeline – Weld x Male Threaded End



VALVE WITH CURB NUT

FEMALE THREADED END – 285 PSI – ANSI 150					
Size	Catalog number	Port	Length	MAOP	Weight
2"	2 BMFT 285 PLRP CB 14S	1.57	6.50	285	11
3"	3 BMFT 285 PLRP CB 14S	2.48	8.13	285	18
4"	4 BMFT 285 PLRP CB 14S	3.10	9.37	285	29

FEMALE THREADED END - 500 PSI					
Size	Catalog number	Port	Length	MAOP	Weight
2"	2 BMFT 500 PLRP CB 14S	1.57	6.50	500	11
3"	3 BMFT 500 PLRP CB 14S	2.48	8.13	500	17
4"	4 BMFT 500 PLRP CB 14S	3.10	9.37	500	29

FEMALE THREADED END – 740 PSI – ANSI 300					
Size	Catalog number	Port	Length	MAOP	Weight
2"	2 BMFT 740 PLRP CB 14S	1.57	6.50	740	11

WELD X MPT THREAD– 285 PSI – ANSI 150					
Size	Catalog number	Port	Length	Wall	Weight
3/4" <sup>(1)</sup>	3/4 BMWM 285 PLRP SB 25S	0.59	9.02	0.113	3
3/4"	3/4 BMWM 285 PLRP SB 14S	0.59	9.02	0.113	5
1" <sup>(1)</sup>	1 BMWM 285 PLRP SB 25S	0.79	9.06	0.133	4
1"	1 BMWM 285 PLRP SB 14S	0.79	9.06	0.130	6
1-1/4"	5/4 BMWM 285 PLRP CB 14S	1.00	10.24	0.140	7
2"	2 BMWM 285 PLRP CB 14S	1.54	11.81	0.154	11

WELD X MPT THREAD - 740 PSI - ANSI 300					
Size	Catalog number	Port	Length	Wall	Weight
3/4" <sup>(1)</sup>	3/4 BMWM 285 PLRP SB 25S	0.59	9.02	0.113	3
3/4"	3/4 BMWM 285 PLRP SB 14S	0.59	9.02	0.113	5
1" <sup>(1)</sup>	1 BMWM 285 PLRP SB 25S	0.79	9.06	0.133	4
1"	1 BMWM 285 PLRP SB 14S	0.79	9.06	0.130	6
1-1/4"	5/4 BMWM 285 PLRP CB 14S	1.00	10.24	0.140	7
2"	2 BMWM 285 PLRP CB 14S	1.54	11.81	0.154	11

Dimensions listed in inch and pound.

<sup>(1)</sup> Curb nut.

## Premium

**High-end valve made with extra-strong forged components.  
Short-pattern design is ideal for metering and regulating stations.**

Manufactured from high strength machined carbon steel material, they can be used in below ground or above ground applications.

### These valves feature:

- Stainless steel balls and stem standard
- Quarter-turn operations
- Locking plate with POWERSTOPS™ 600 ft/lbs
- Seats of 25% carbonized PTFE (Teflon™) (G-453) rated to -20°F
- Zinc coated stem bearings
- Tested per API-6D requirements
- Serial numbered for full traceability

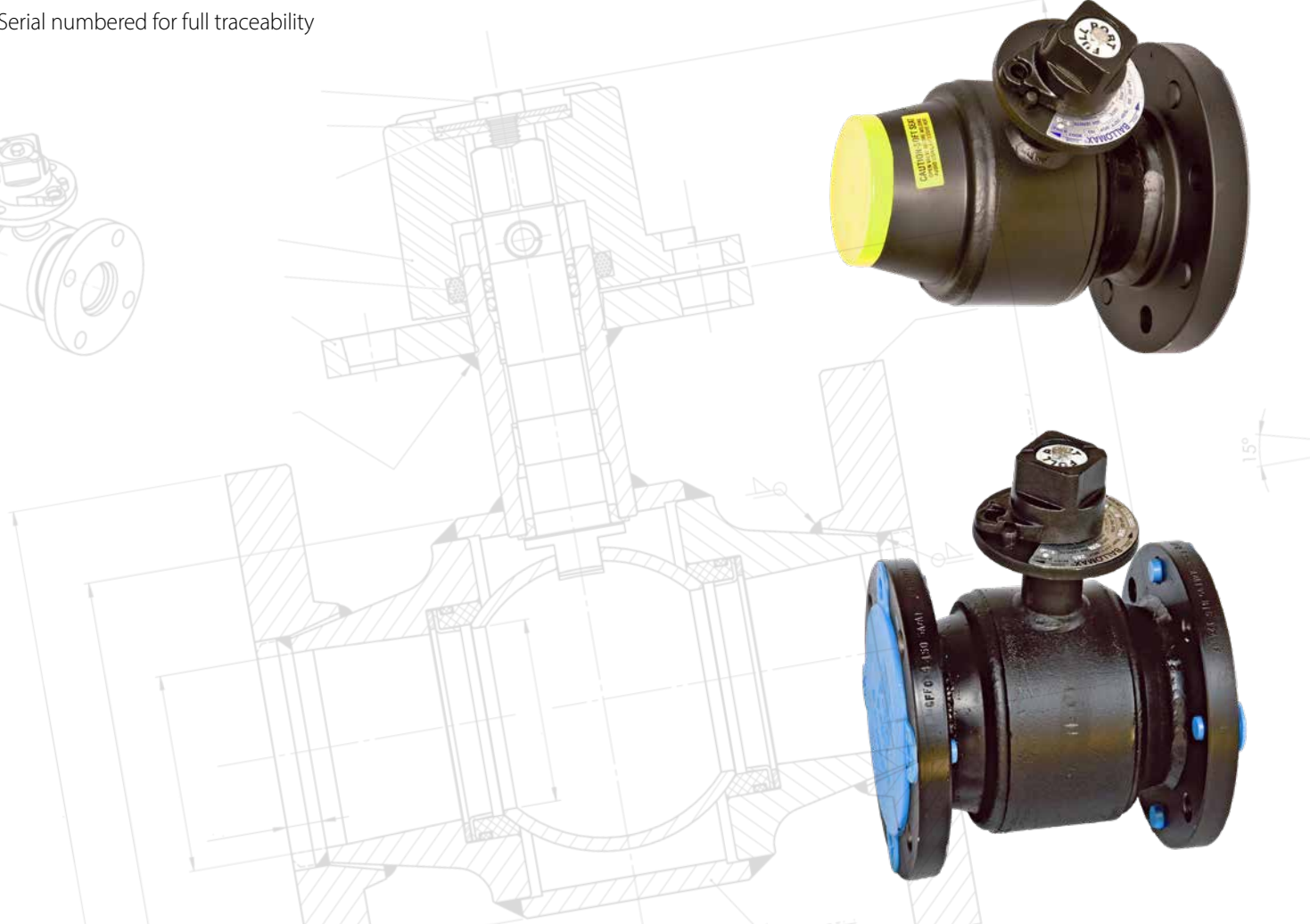
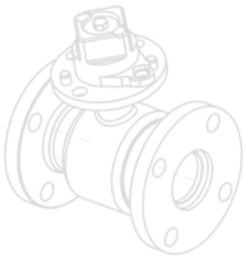

15°

## Premium – Full Port Floating Ball Valve

WELD X WELD – 285 PSI – ANSI 150					
Size	Catalog number	Port	Length	Wall	Weight
2"	2 BMW 285 PRFP CB 14S	1.93	7.00	0.154	13
3"	3 BMW 285 PRFP CB 14S	3.07	9.00	0.216	23
4"	4 BMW 285 PRFP CB 14S	3.86	9.75	0.237	35
6"	6 BMW 285 PRFP CB 14S	5.75	15.50	0.280	110
8"	8 BMW 285 BFPC BH GS	7.87	20.50	0.322	236

WELD X WELD – 740 PSI – ANSI 300					
Size	Catalog number	Port	Length	Wall	Weight
2"	2 BMW 740 PRFP CB 14S	1.93	7.00	0.154	13
3"	3 BMW 740 PRFP CB 14S	3.07	9.00	0.216	23
4"	4 BMW 740 PRFP CB 14S	3.86	9.75	0.237	35
6"	6 BMW 740 PRFP CB 14S	5.75	15.5	0.280	110

WELD X FLANGE – 285 PSI – ANSI 150					
Size	Catalog number	Port	Length	Wall	Weight
2"	2 BMWF 285 PRFP CB 14S	1.93	7.00	0.154	17
3"	3 BMWF 285 PRFP CB 14S	3.07	9.20	0.216	32
4"	4 BMWF 285 PRFP CB 14S	3.86	10.39	0.237	44
6"	6 BMWF 285 PRFP CB 14S	5.75	15.50	0.280	135
8"	8 BMWF 285 BFPC BH GS	7.87	19.25	0.322	266

WELD X FLANGE – 740 PSI – ANSI 300					
Size	Catalog number	Port	Length	Wall	Weight
2"	2 BMWF 740 PRFP CB 14S	1.93	7.75	0.154	19
3"	3 BMWF 740 PRFP CB 14S	3.07	8.50	0.216	37
4"	4 BMWF 740 PRFP CB 14S	3.86	10.88	0.237	55
6"	6 BMWF 740 PRFP CB 14S	5.75	15.69	0.280	147

FLANGE X FLANGE – 285 PSI – ANSI 150					
Size	Catalog number	Port	Length	ANSI	Weight
2"	2 BMF 285 PRFP CB 14S	1.93	7.00	150	22
3"	3 BMF 285 PRFP CB 14S	3.07	8.00	150	41
4"	4 BMF 285 PRFP CB 14S	3.86	9.00	150	57
6"	6 BMF 285 PRFP CB 14S	5.75	15.50	150	150
8"	8 BMF 285 BFPC BH GS	7.87	18.00	150	296

FLANGE X FLANGE – 740 PSI – ANSI 300					
Size	Catalog number	Port	Length	ANSI	Weight
2"	2 BMF 740 PRFP CB 14S	1.93	8.50	300	26
3"	3 BMF 740 PRFP CB 14S	3.07	11.13	300	50
4"	4 BMF 740 PRFP CB 14S	3.86	12.00	300	71
6"	6 BMF 740 PRFP CB 14S	5.75	15.88	300	180

Dimensions listed in inch and pound.

## Premium BALLOTAP™ – Hot Tapping Ball Valve

Fully welded, machined carbon steel full port ball valves designed with a weld end and a threaded end that accepts a special BALLOTAP™ threaded flange for use in tapping under pressure of natural gas pipelines.

Valve works with all common drilling and tapping machines currently on the market. O-ring seal in flange allows for pressure testing of weld prior to tapping.

### These valves feature:

- Stainless steel balls and stem standard
- 2" square nut operated
- Locking plate with POWERSTOPS™ to prevent over turning
- Seats of 25% carbonized PTFE (Teflon™) (G-453) rated to -20°F
- Zinc coated stem bearings
- Tested per API-6D requirements
- Serial numbered for full traceability
- Full port design



BALLOTAP™ VALVES – 285 PSI – ANSI 150					
Size	Catalog number	Port	Length	Wall	Weight
2"	2 BMHT 285 PRFP CB 14S	1.93	7.00	0.154	13
4"	4 BMHT 285 PRFP CB 14S	3.86	10.39	0.237	33
6"	6 BMHT 285 PRFP CB 14S	5.75	15.50	0.280	110

BALLOTAP™ VALVES – 740 PSI – ANSI 300					
Size	Catalog number	Port	Length	Wall	Weight
2"	2 BMHT 740 PRFP CB 14S	1.93	7.00	0.154	13
4"	4 BMHT 740 PRFP CB 14S	3.86	10.39	0.237	33
6"	6 BMHT 740 PRFP CB 14S	5.75	15.50	0.280	110

BALLOTAP™ – REMOVABLE FLANGES – 285 PSI – ANSI 150			
Size	Catalog number	ANSI	Weight
2"	2 F 150 BT	150	5
4"	4 F 150 BT	150	13
6"	6 F 150 BT	150	19

BALLOTAP™ – REMOVABLE FLANGES – 740 PSI – ANSI 300			
Size	Catalog number	ANSI	Weight
2"	2 F 300 BT	300	7
4"	4 F 300 BT	300	22
6"	6 F 300 BT	300	39

Dimensions listed in inch and pound.

## Utility – Flanged Ball Valves

Cost-effective short pattern flanged end ball valve. Ideal to replace plug and iron body valves.

### These valves feature:

- Stainless steel balls and stem standard
- Wrench nut or lever handle operated
- Locking lugs
- Seats of 25% carbonized PTFE (Teflon™) (G-453) rated to -20°F
- Zinc coated stem bearings
- Tested per API-6D requirements
- Serial numbered for full traceability
- High strength boiler plate flanges drilled to ANSI 150 pattern



### RAISED FACE

#### 285 PSI – ANSI 150 – WITH WRENCH NUT

Size	Catalog number	Port	Length	ANSI	Weight
2"	2 BMF 285 UVRP CB 03S	1.54	7.00	150	11
3"	3 BMF 285 UVRP CB 03S	2.48	8.00	150	19
4"	4 BMF 285 UVRP CB 03S	3.07	9.00	150	33
6"	6 BMF 285 UVRP CB 03S	4.80	10.50	150	68

### FLAT FACE

#### 285 PSI – ANSI 150 – WITH WRENCH NUT

Size	Catalog number	Port	Length	ANSI	Weight
2"	2 BMF 285 UVRP CB 03SFF	1.54	7.00	150	11
3"	3 BMF 285 UVRP CB 03SFF	2.48	8.00	150	19
4"	4 BMF 285 UVRP CB 03SFF	3.07	9.00	150	32
6"	6 BMF 285 UVRP CB 03SFF	4.80	10.50	150	68

#### 285 PSI – ANSI 150 – WITH HANDLE

Size	Catalog number	Port	Length	ANSI	Weight
2"	2 BMF 285 UVRP CB 01S	1.54	7.00	150	11
3"	3 BMF 285 UVRP CB 01S	2.48	8.00	150	19
4"	4 BMF 285 UVRP CB 01S	3.07	9.00	150	34
6"	6 BMF 285 UVRP CB 01S	4.80	10.50	150	72

#### 285 PSI – ANSI 150 – WITH HANDLE

Size	Catalog number	Port	Length	ANSI	Weight
2"	2 BMF 285 UVRP CB 01SFF	1.54	7.00	150	11
3"	3 BMF 285 UVRP CB 01SFF	2.48	8.00	150	19
4"	4 BMF 285 UVRP CB 01SFF	3.07	9.00	150	33
6"	6 BMF 285 UVRP CB 01SFF	4.80	10.50	150	71

Dimensions listed in inch and pound.

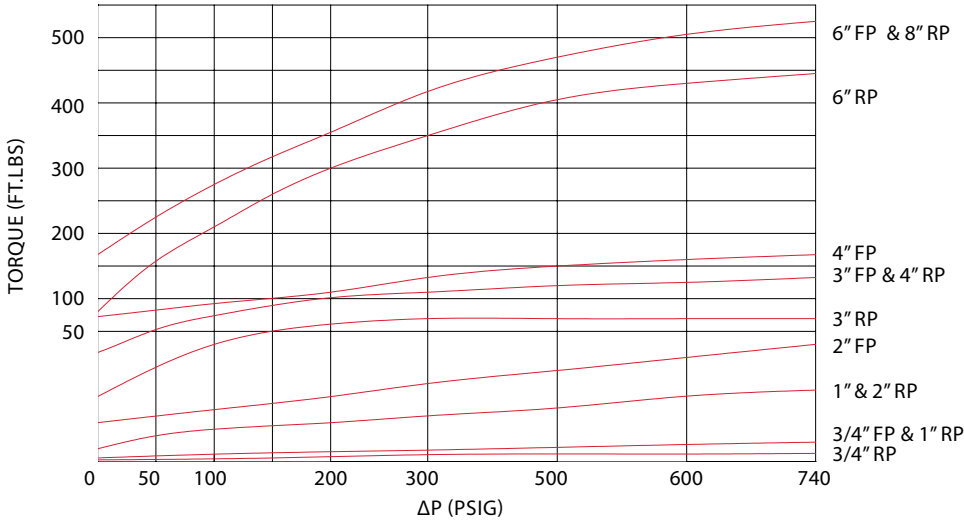

## Turning Torque For 3/4" - 8" BROEN BALLOMAX® Reduced Port and Full Port

The torque must be considered as a recommended torque. The torque is derived from measurements taken on newly produced valves. The torque is a break away torque for a closed, but just activated valve. It should be noted: For a valve, which has not been activated for a long period of time, the listed turning torques could be up to 1-1/2 times greater.

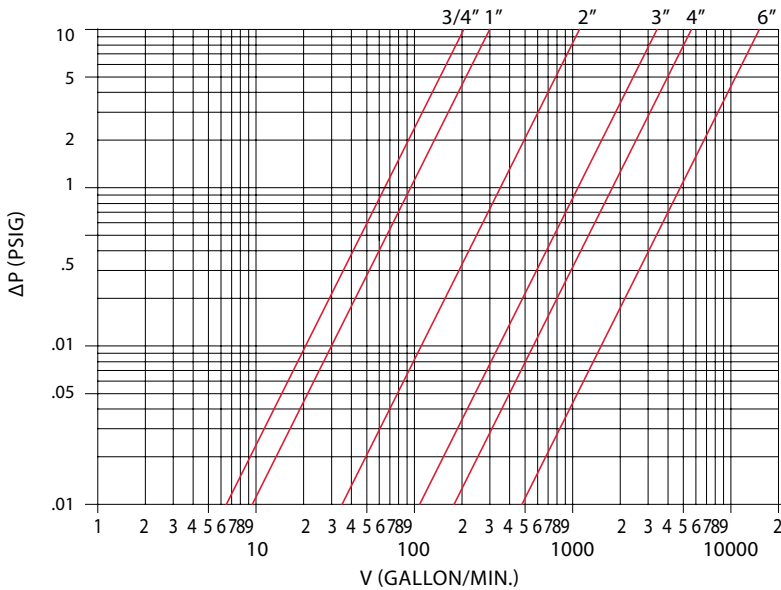

## Pressure Loss Diagram Full Port BROEN BALLOMAX® Ball Valves

$$Cv = \frac{V}{\sqrt{\Delta P}}$$

v = Flow rate in gallon/min

ΔP = Pressure drop in PSI

Dia.	3/4"	1"	2"	3"	4"	6"
Cv	65	94	355	1100	1850	4825

MEDIUM:  
Water with specific gravity of 1.

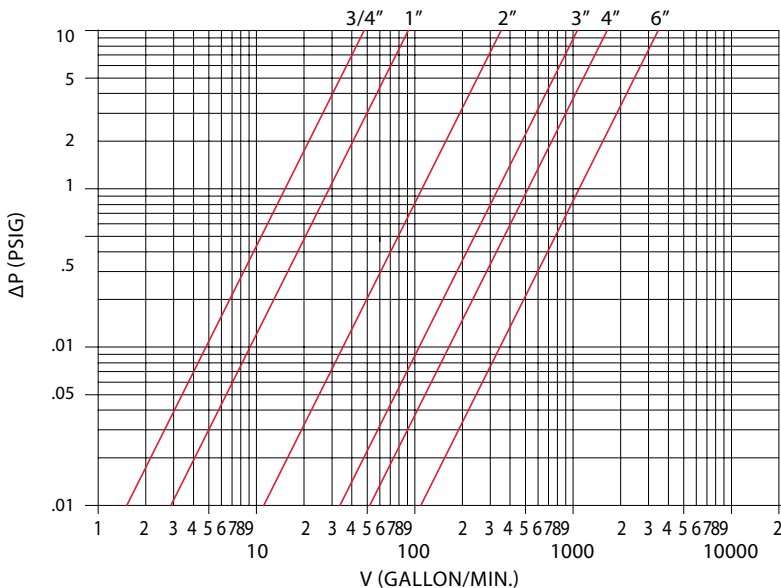

## Pressure Loss Diagram Regular Port BROEN BALLOMAX® Ball Valves

$$Cv = \frac{V}{\sqrt{\Delta P}}$$

v = Flow rate in gallon/min

ΔP = Pressure drop in PSI

Dia.	3/4"	1"	2"	3"	4"	6"
Cv	17	29	116	324	520	1272

MEDIUM:  
Water with specific gravity of 1.

# BROEN BALLOMAX<sup>®</sup>

## NextGen

# BROEN

VALVE TECHNOLOGIES

### Key features

- Designed for Natural Gas service
- Full Port
- Sizes: 2"
- Class 150 or 300
- MAOP: 285 or 740 PSI
- Temperature range: -20F to 250F

#### ADVANCED TRACEABILITY

A unique serial number, permanently stamped on a stainless-steel nameplate, ensures full traceability. MTRs and pressure test records provide complete documentation and Quality Assurance.

#### LOCK PLATE WITH ISO BOLT PATTERN

The standard ISO bolt pattern simplifies the installation of gearboxes or actuators when needed.

#### ENHANCED STEM SEALING

The valve features a redundant stem sealing system designed to minimize the risk of stem leaks while meeting API 641 fugitive emissions requirements, ensuring superior reliability and environmental compliance.

#### OPTIMIZED OPERATING NUTS

Engineered for superior performance, it minimizes operational risks by eliminating pinching hazards through a redesigned stop pin system.

#### STREAMLINED BODY

The world's most compact valve body design delivers exceptional lightweight performance without compromising wall thickness, structural integrity, or reliability.

#### FULL PORT DESIGN

The full port ball maximizes flow efficiency and minimizes pressure drop, all while maintaining a highly competitive price.

#### PATENTED LASER WELDING

Our full-penetration robotic laser welding technology ensures exceptional precision, consistency, and efficiency while enhancing durability and leak-proof performance.

#### END CONNECTION TECHNOLOGIES

The valve is available in a variety of configurations, including Flanged ends, Weld ends, and more, with multiple length options to suit different installation requirements.

THE FUTURE IS HERE



Enhanced valve identification

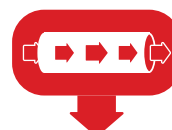

Full port design



Reduced weight



Sustainability

*Our brand is our promise*

**BROEN**  
VALVE TECHNOLOGIES

### **BROEN VALVE TECHNOLOGIES**

BROEN is a leading international manufacturer of valve technology and we operate on three continents across the world with key markets in Europe, China and USA.

For more than 75 years BROEN has been the global leader in the development and production of valve technology for the control of water, air and gas. BROEN delivers complete solutions for HVAC building installations and is a leading supplier of district energy valves and valve technology for natural gas.

We know application and valve technology in depth and in close dialogue with our customers and partners all over the world we create value and reliability with proven valves offering full quality assurance.

Read more at: [www.broen.us](http://www.broen.us)

#### **Sales- and productions sites ●**

BROEN A/S, Assens (DK)  
BROEN POLAND, Dzierżoniów (PL)  
BROEN POLAND, Rogoźno (PL)  
BROEN INC., Houston (US)  
BROEN Clorius, Dzierżoniów (PL)

#### **Sales companies and offices ○**

BROEN Assens (DK)  
BROEN Helsinki (FI)  
BROEN Beijing (CN)  
BROEN Clorius, Shanghai (CN)



### **BROEN INC.**

6421 Lozano Drive, Houston, TX 77041 USA

+1 713.300.0480 | [info@BROEN.com](mailto:info@BROEN.com) | [www.BROEN.us](http://www.BROEN.us)